

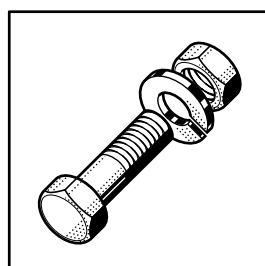

FE-W

Spare Parts
Pièces Détachées
Ersatzteile
Onderdelen



Electrical components listed in this catalogue are rated for the following supply voltages:

Les composants électriques énumérés dans ce catalogue sont prévus pour les tensions suivantes:

Die in diesem Katalog aufgeführten Elektroteile beziehen sich auf folgende Anschlußspannungen:

De in deze catalogus afgebeelde elektrische componenten zijn geschikt voor de volgende aansluitspanningen:

200-230V / 50Hz / 1 / N / PE

380-415V / 50Hz / 3 / N / PE

380-415V / 60Hz / 3 / N / PE

200V / 60Hz / 1 / N / PE

For other voltages, refer to the wiring diagram shipped with the machine.

Pour d'autres tensions, se référer au schéma électrique envoyé avec la machine.

Bei nicht aufgeführten Anschlußspannungen bitte den, der Maschine beigelegten, Schaltplan beachten.

Voor eventueel andere aansluitspanningen, raadpleeg het elektrische schema welke zich bij de machine bevind.

Contents

Panels	4
Frame and door	5
Filter and tank	6
Booster, fill and rinse pump	7
Wash pump	8
Wash and rinse system	9
Dispensers and drain	10
Contro panel and electrical parts	11

Sommaire

Panneaux	4
Châssis et porte	5
Filtre et bac	6
Chaudière, remplissage et pompe de rinçage	7
Pompe de lavage	8
Système de lavage et de rinçage	9
Doseurs et vidange	10
Panneau de commande et pièces de électriques	11

Inhalt

Verkleidungen	4
Gestell und Tür	5
Sieb und Tank	6
Erhitzer, Fülleitung und Klarspülpumpe	7
Waschpumpe	8
Wasch- und Klarspülsystem	9
Dosiergeräte und Ablauf	10
Schalterblende und Elektroteile	11

Inhoud

Panelen	4
Frame en deur	5
Zeef en tank	6
Booster, vulleiding en Naspoelpomp	7
Waspomp	8
Was- en spoelsysteem	9
Doseerapparaten en afvoer	10
Schakelpanel en elektrische delen	11

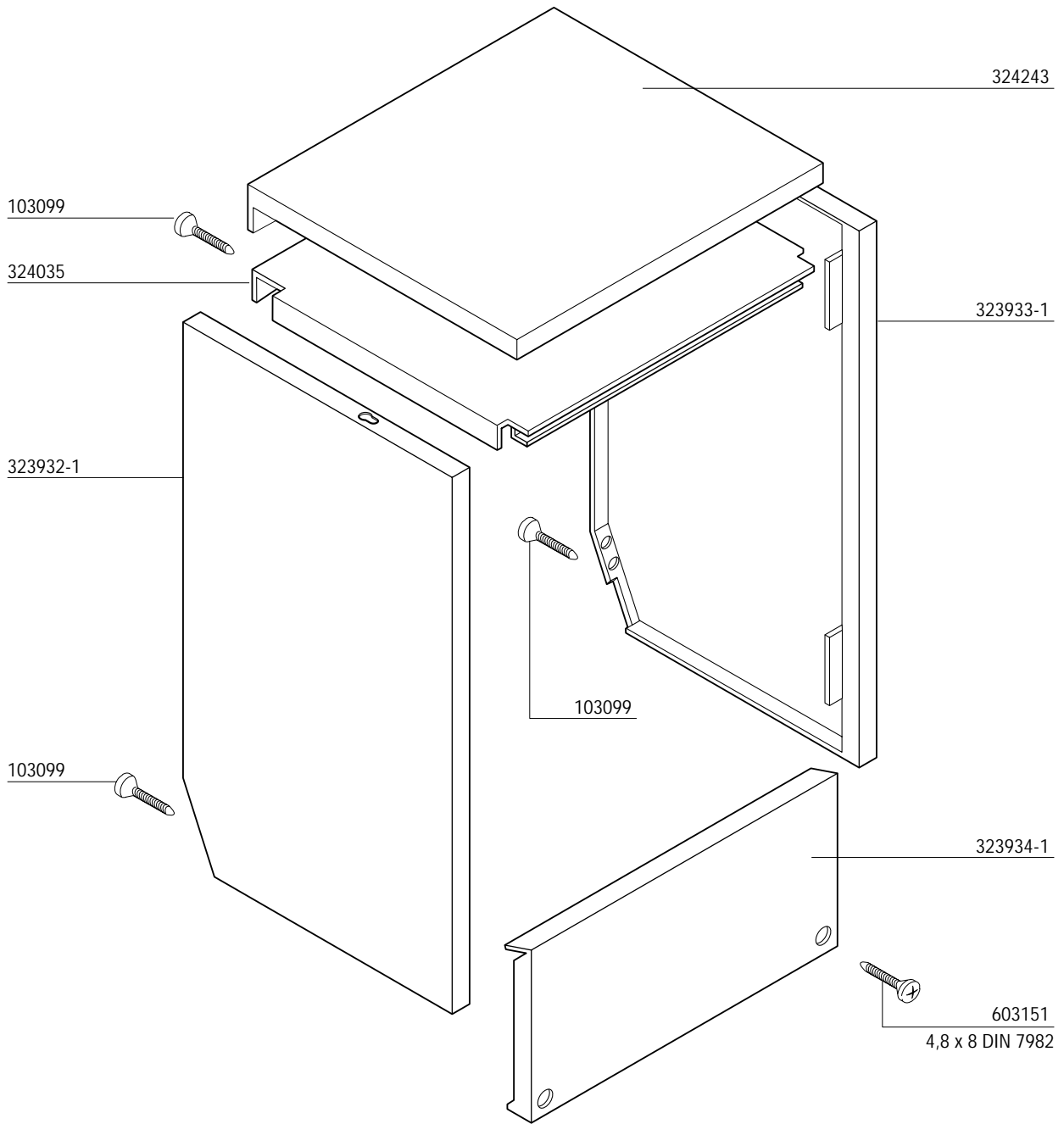

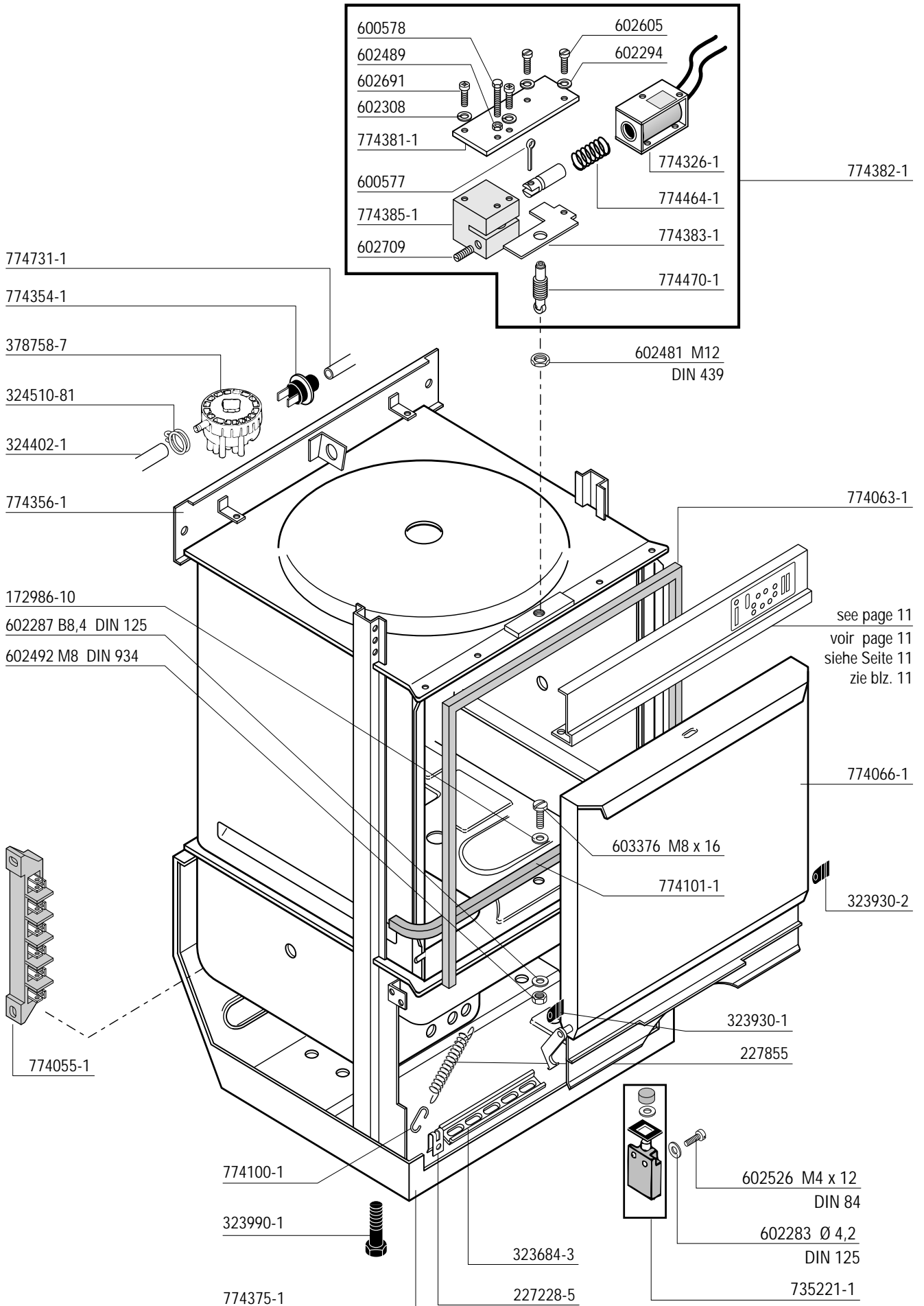

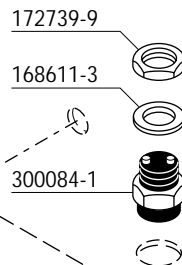
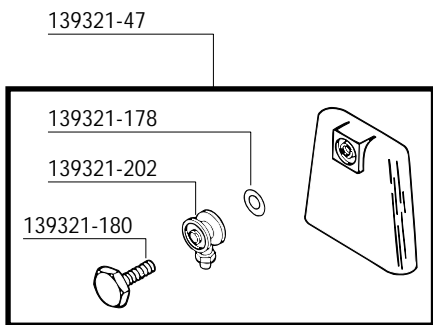
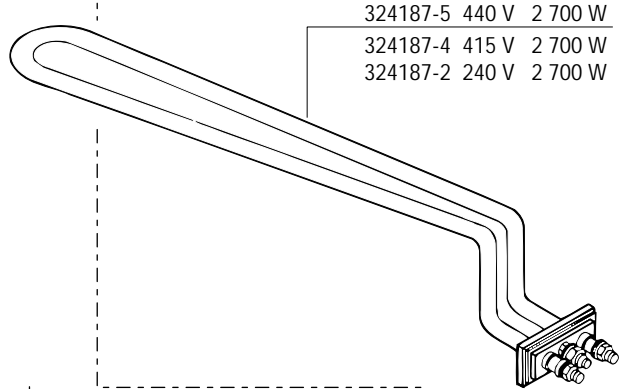
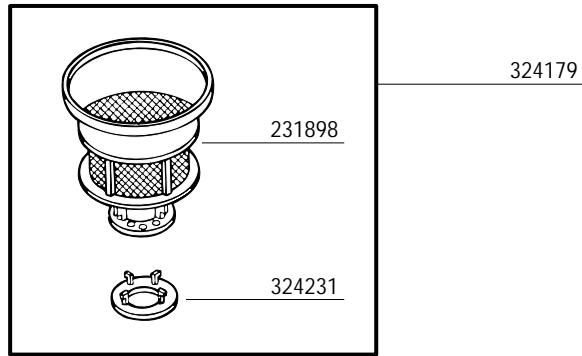
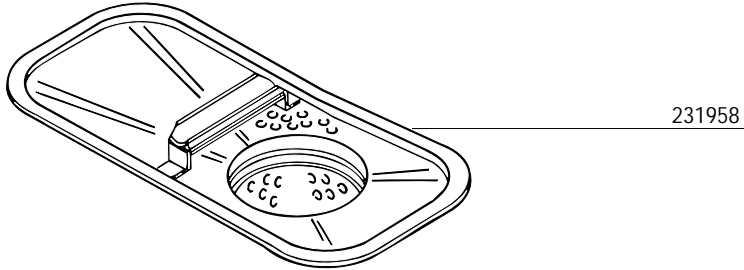

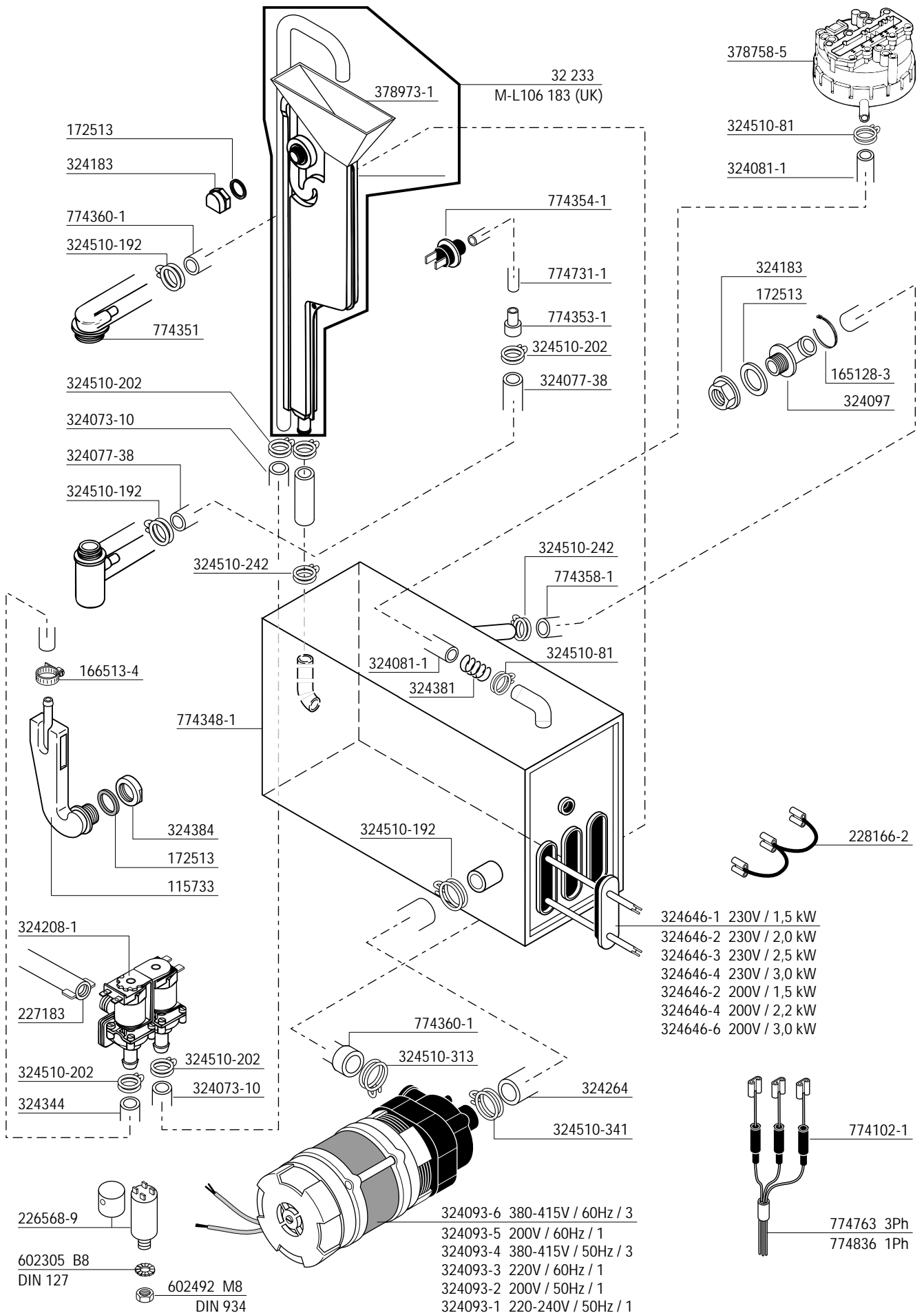

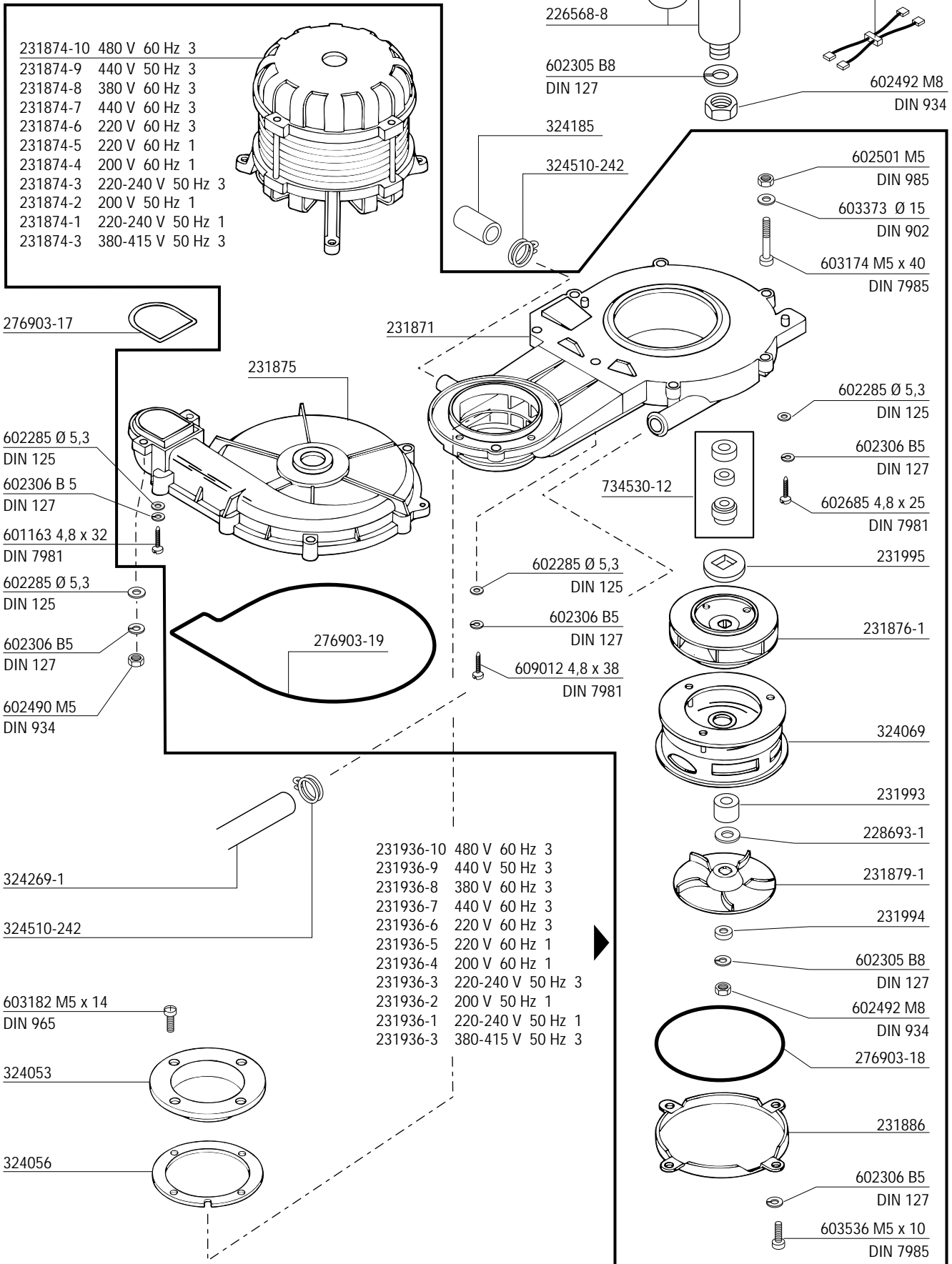

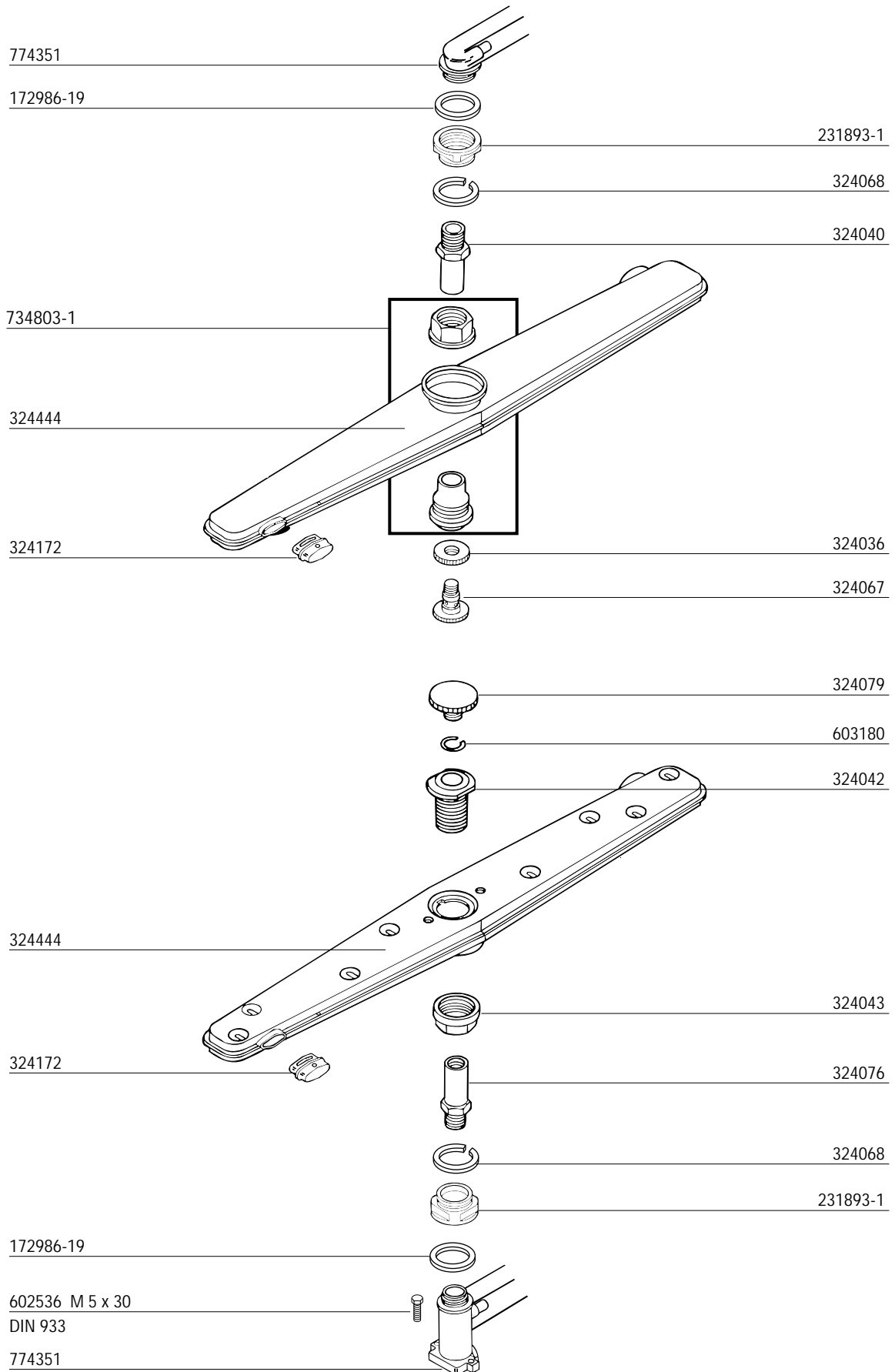

Dispensers
 Doseurs
 Dosiergeräte
 Doseerapparaten

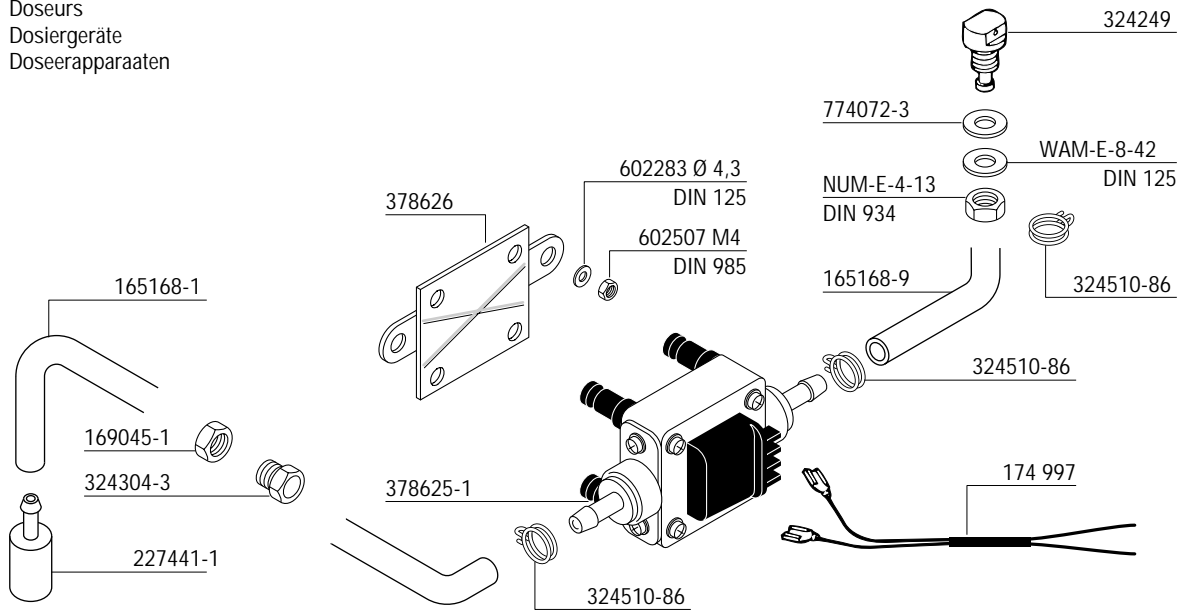

detergent
 détergent
 Reiniger
 wasmiddel

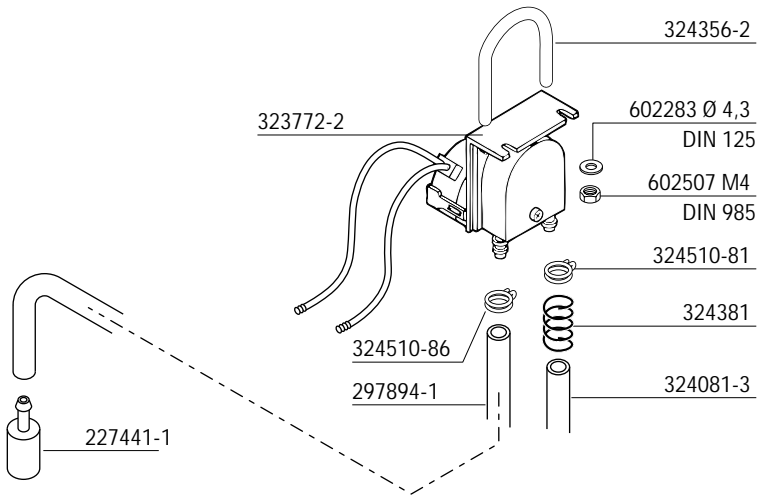

rinse agent
 produit de rinçage
 Klarspüler
 naspelmiddel

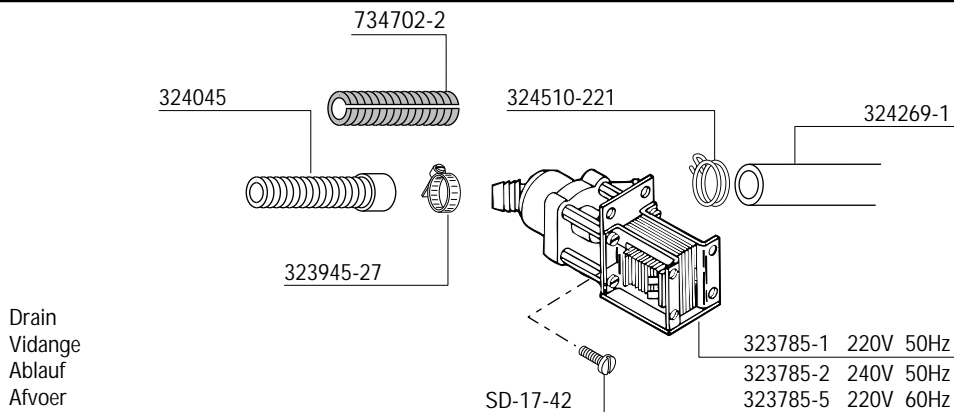

Drain
 Vidange
 Ablauf
 Afvoer

